

Verdrehgesicherter  
pneumatischer  
**Kurzhubzylinder**  
**Kompakte Baureihe**  
**JDR**

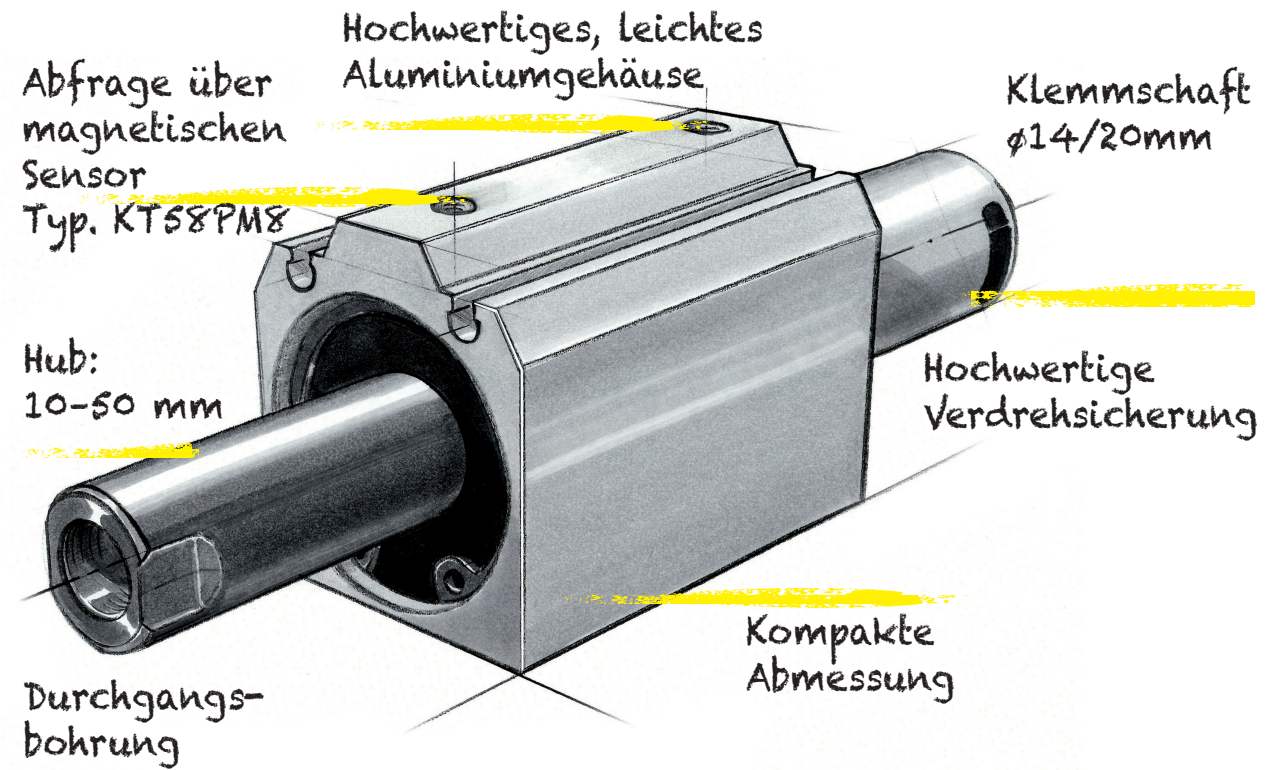

Stand 03.2016  
Technische Änderungen vorbehalten.

fon +49 7 31-8 80 25 60  
direct +49 1 79-2 99 20 64  
www.gts-p.de  
info@gts-p.de

Kompetenz greifbar

Verdrehgesicherter  
pneumatischer  
**Kurzhubzylinder**  
**Kompakte Baureihe**  
**JDR**

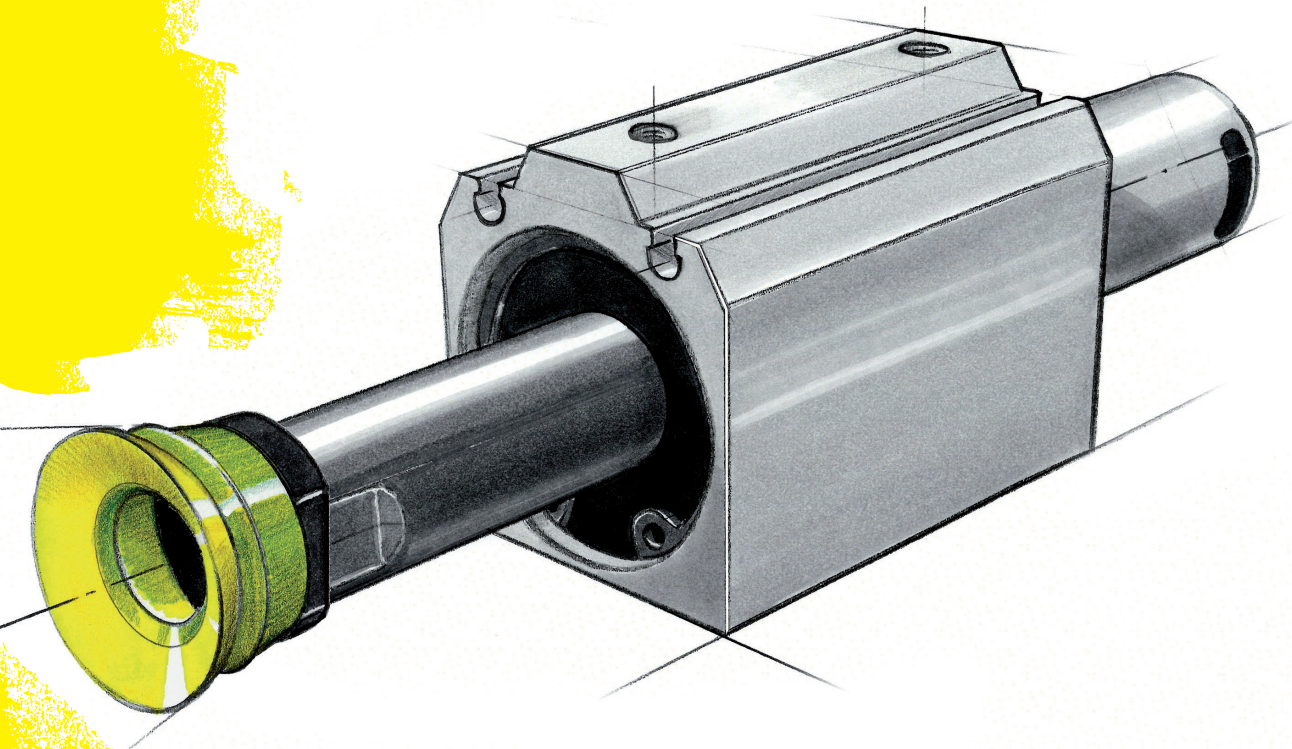

Greif-Technik-Schmid GmbH  
Schulze-Delitzsch-Weg 30  
89079 Ulm-Wiblingen  
fon +49 7 31-8 80 25 60  
fax +49 7 31-8 80 25 62  
direct +49 179-2 99 20 64  
info@gts-p.de

Partner of



powered by FP-Services

**FP SERVICES**  
AUTOMATION



**Made in Italy!**  
**Nur bei GTS!**

# Verdrehgesicherter pneumatischer Kurzhubzylinder kompakt



## GT.JDR.14

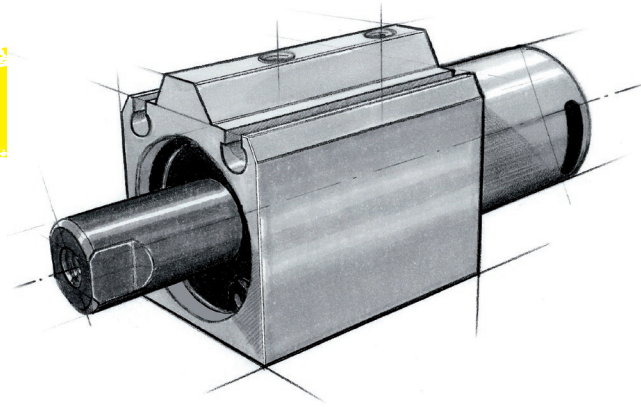

Bestell-Nr.	Klemm- $\phi$ mm	Hub mm	Anschluss Vakuum/Druckluft	A mm	B mm	C mm	D sw	E mm	Gewicht (g)
GT.JDR.14.10.5	14	10	M5/M5	74,2	24	29	8	19	54
GT.JDR.14.25.5	14	25	M5/M5	119,2	24	29	8	19	76

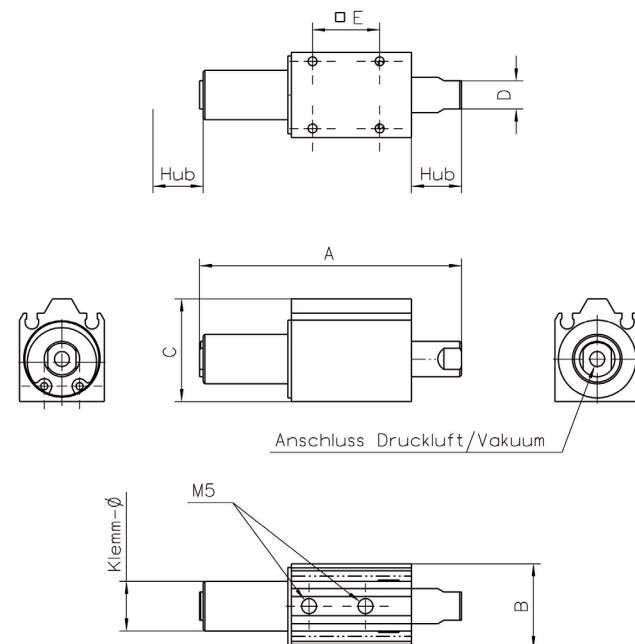

Stand 03.2016  
Technische Änderungen  
vorbehalten.

fon +49 7 31-8 80 25 60  
direct +49 1 79-2 99 20 64  
www.gts-p.de  
info@gts-p.de

**Kompetenz greifbar**

# Verdrehgesicherter pneumatischer Kurzhubzylinder kompakt



## GT.JDR.20

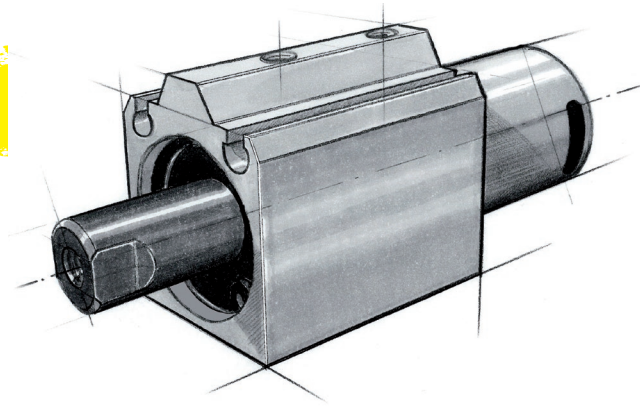

Bestell-Nr.	Klemm- $\phi$ mm	Hub mm	Anschluss Vakuum/Druckluft	A mm	B mm	C mm	D sw	E mm	Gewicht (g)
GT.JDR.20.10.5	20	10	M5/M5	74,2	24	29	8	19	63

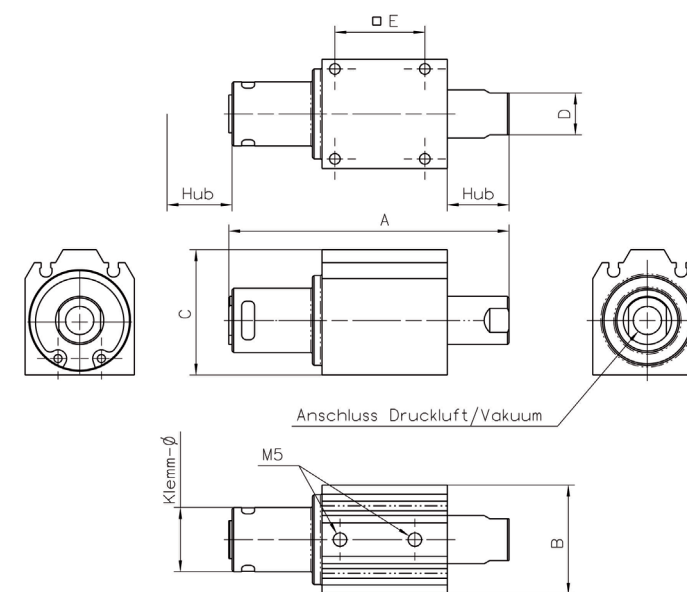

Stand 03.2016  
Technische Änderungen  
vorbehalten.

fon +49 7 31-8 80 25 60  
direct +49 1 79-2 99 20 64  
www.gts-p.de  
info@gts-p.de

**Kompetenz greifbar**

# Verdrehgesicherter pneumatischer Kurzhubzylinder kompakt



## GT.JDR.30

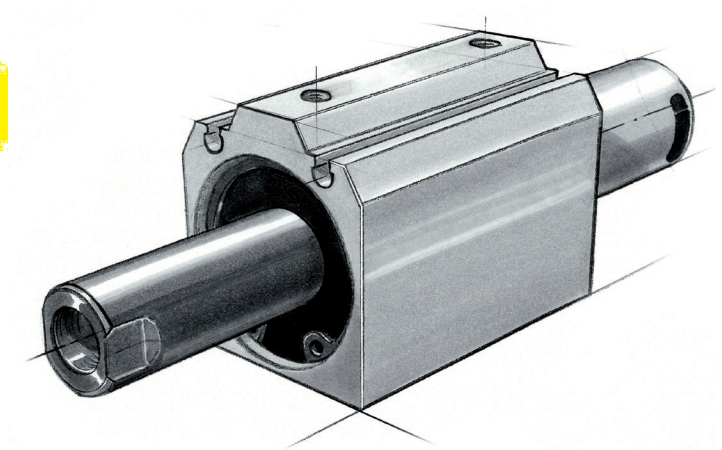

Bestell-Nr.	Klemm- $\phi$ mm	Hub mm	Anschluss Vakuum/Druckluft	A mm	B mm	C mm	D sw	E mm	Gewicht (g)
GT.JDR.30.15.18	20	15	G1/8 / M5	87,2	34	39	13	28	112
GT.JDR.30.30.18	20	30	G1/8 / M5	130,2	34	39	13	28	150
GT.JDR.30.50.18	20	50	G1/8 / M5	190,2	34	39	13	28	200

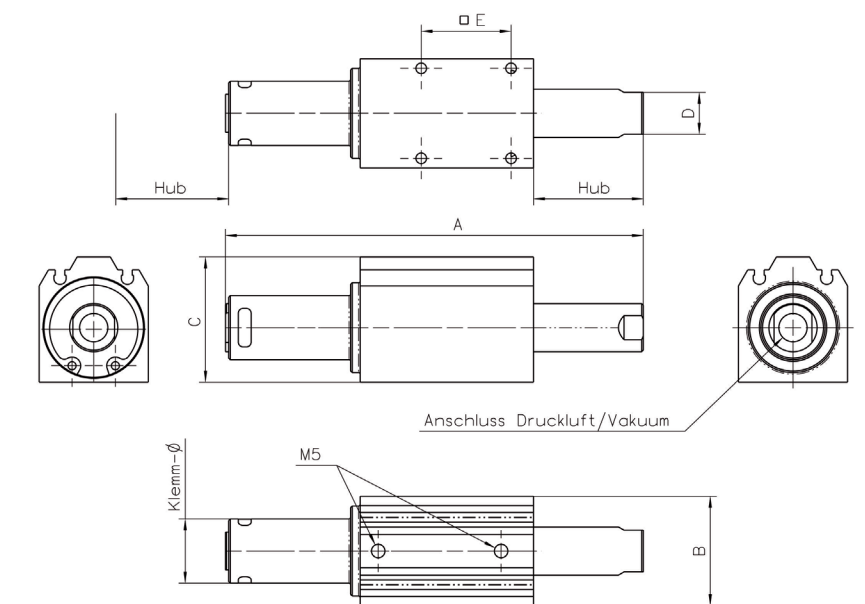

Stand 03.2016  
Technische Änderungen  
vorbehalten.

fon +49 7 31-8 80 25 60  
direct +49 1 79-2 99 20 64  
www.gts-p.de  
info@gts-p.de

**Kompetenz greifbar**